



INTERNATIONAL PRESTRESSED
HOLLOWCORE ASSOCIATION

IPHA Annual Conference 2015



Getting It Right in South Africa

Presented By Monique Eggebeen (Managing Director)
ECHO Group

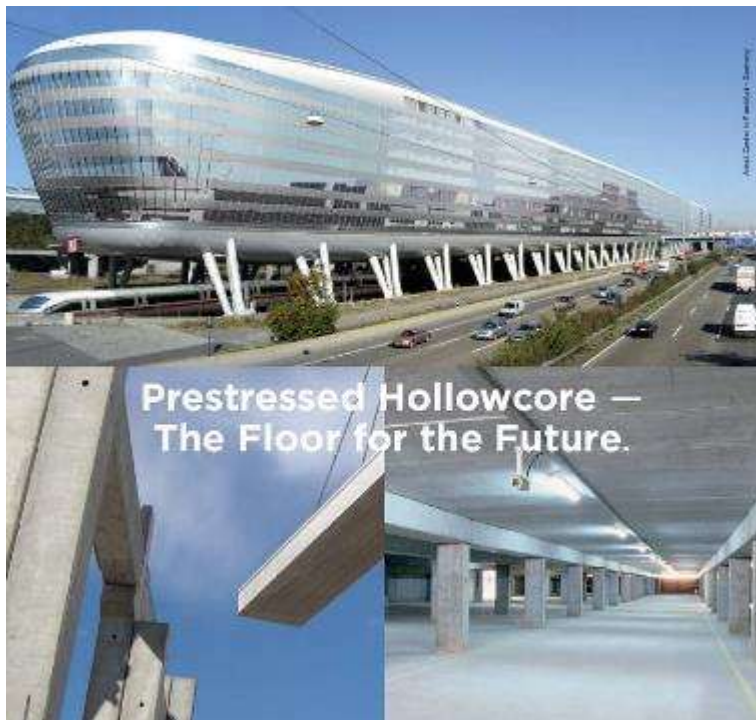

Prestressed Hollowcore —
The Floor for the Future.

The difficult years...

- Prior to the Global Recession –
 - Industrial Action – supply and demand constraints
 - Sole Hollowcore Supplier in regional market (Gauteng)
 - Competitor – Price War & memory of industrial action
- Highlighted shortfall on dependency w.r.t commodity application – strategy re-alignment.
 - Commercial / industrial application
 - Alternative applications
 - Precast supporting elements – create precast culture
- Organizational and Operational Streamlining
 - Increased capacity – continuous shift system to increase production
 - Consolidation of marketing/sales and administration within the group
- Expanding our national footprint
 - Echo Prestress - KZN
 - Topfloor – Cape Town



The Doom, the Gloom, the Boom

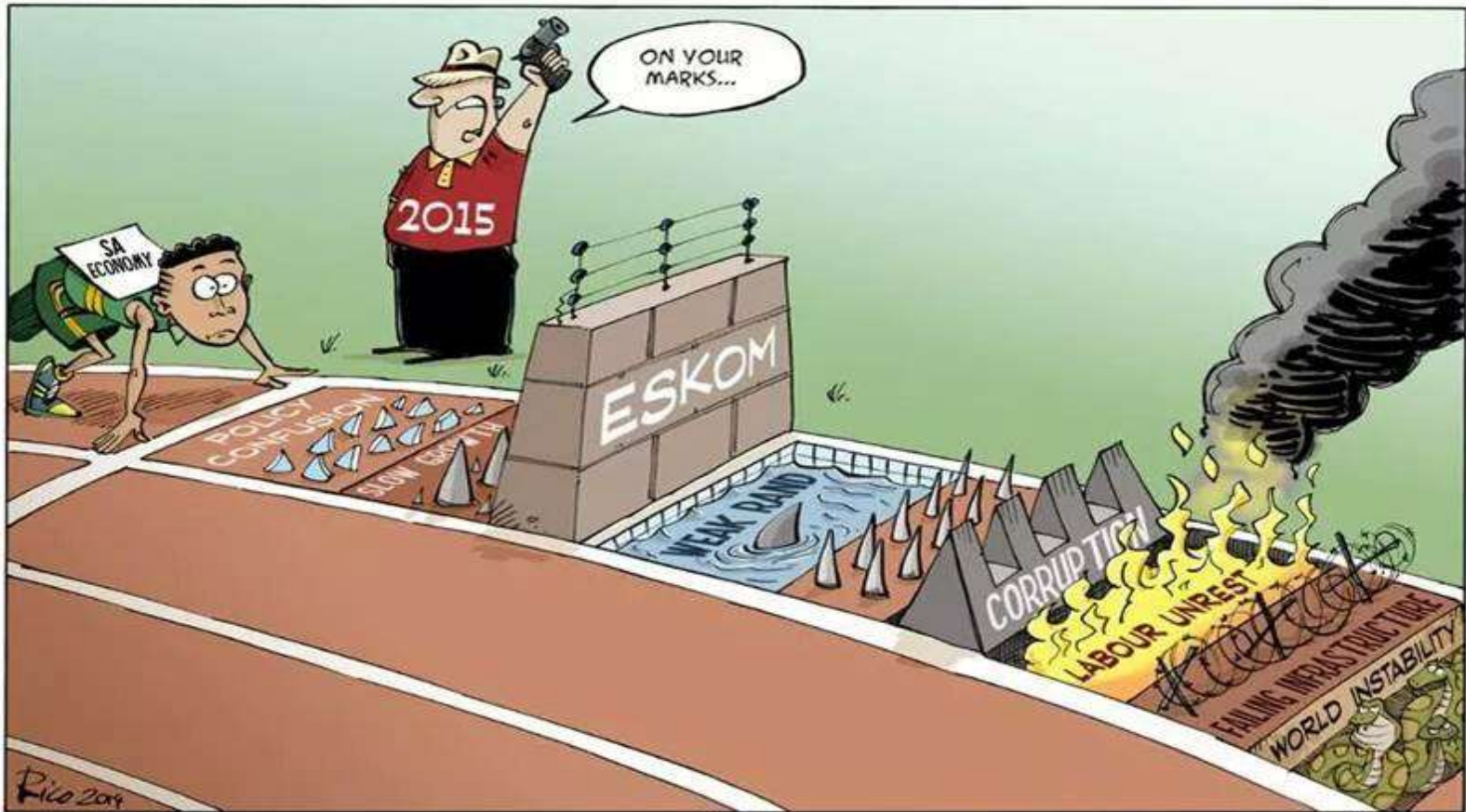

Current housing challenge

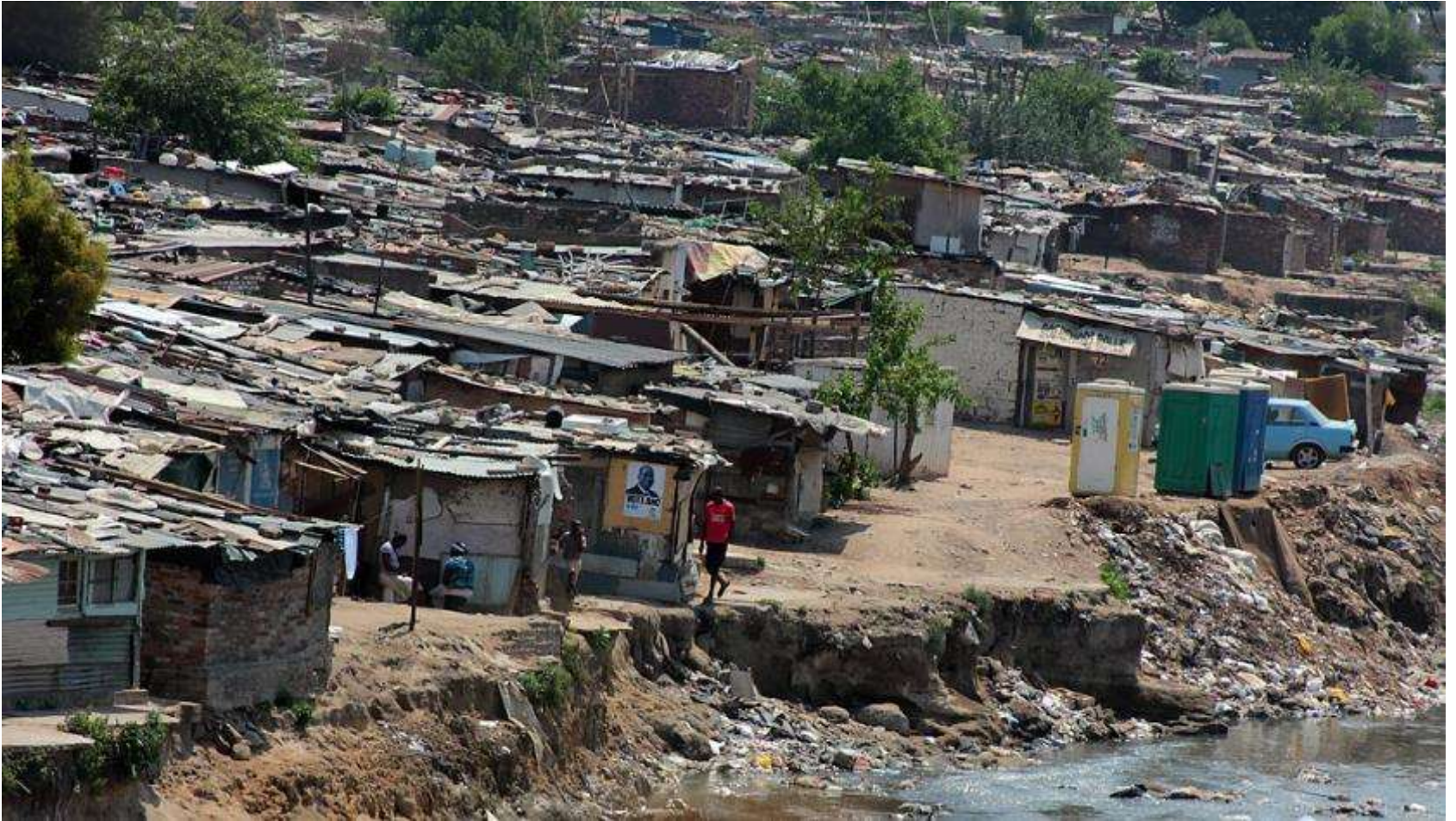

Affordable housing solution in South Africa



Three and Four Storey Walk-ups



Current reality

- Urbanization
 - Suitable land shortages
- Housing back-log
 - Stands at 2.3 million
- Local unskilled labour
 - Rely on load bearing masonry
 - Quality of workmanship

SA Affordable Housing
Infrastructure & Development
www.trademax.co.za



HOLLOW-CORE CONCRETE FLOORING



FIRST 6 STOREY HOLLOWCORE BUILDING

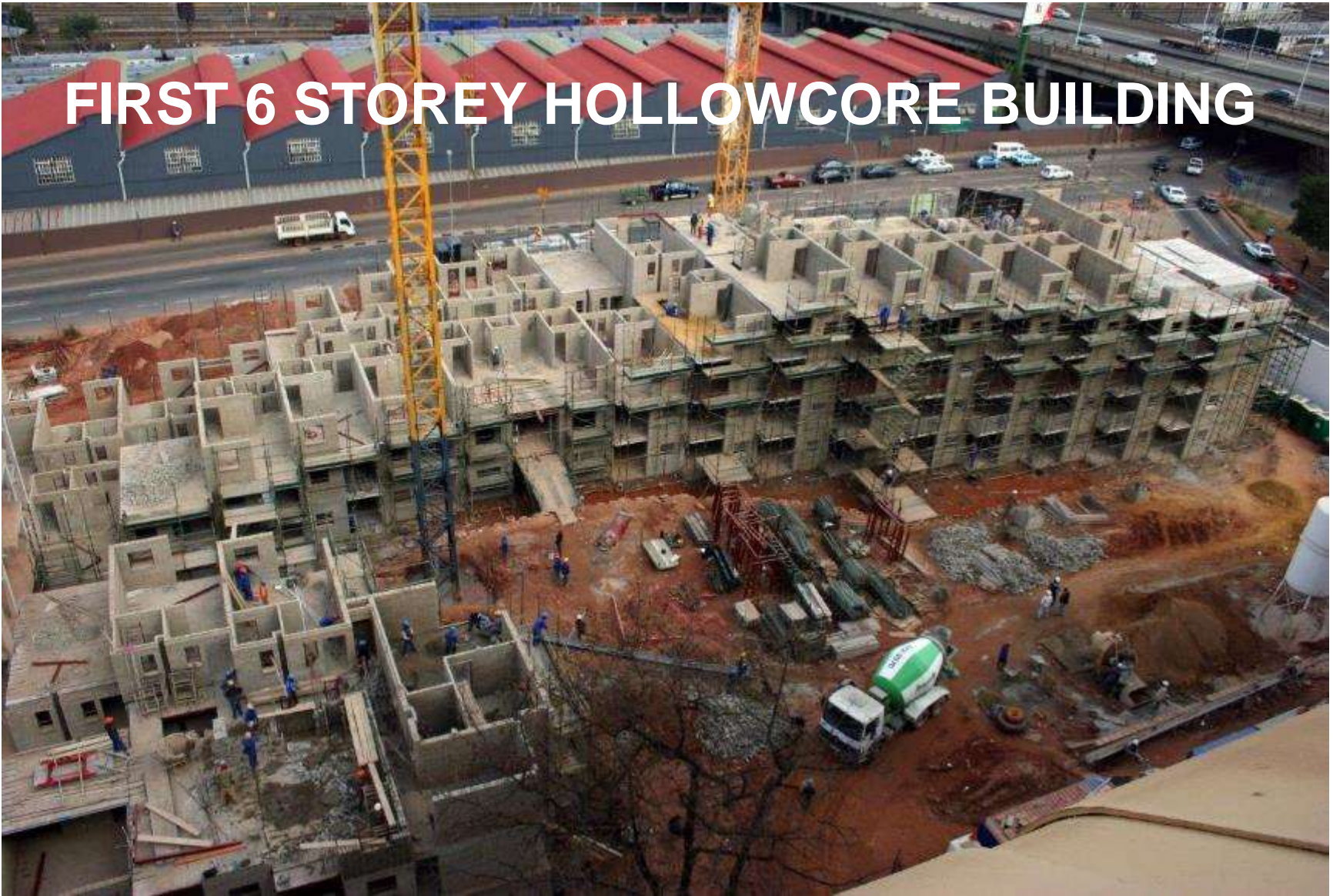

Hollowcore for Commercial Office Blocks



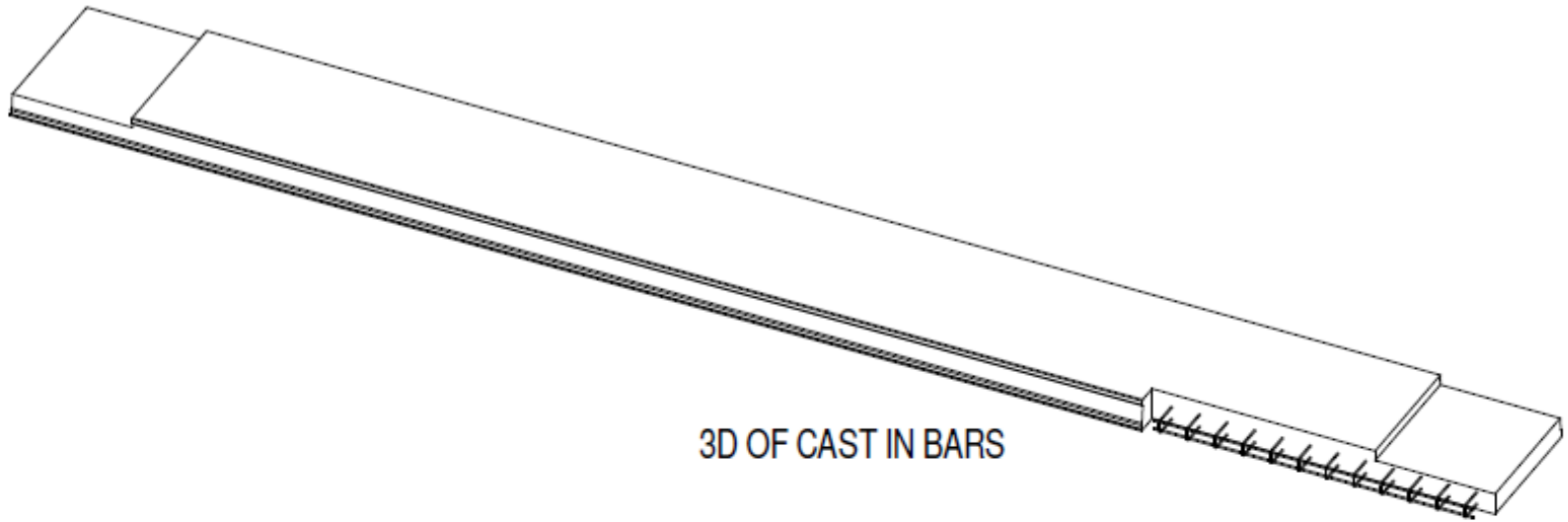

250mm stepdown to 170mm

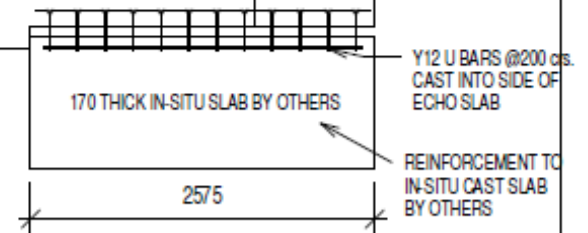

PLAN ON IN-SITU SLAB FIXING DETAIL

CLEARWATER OFFICE BLOCK

Stadium Seating



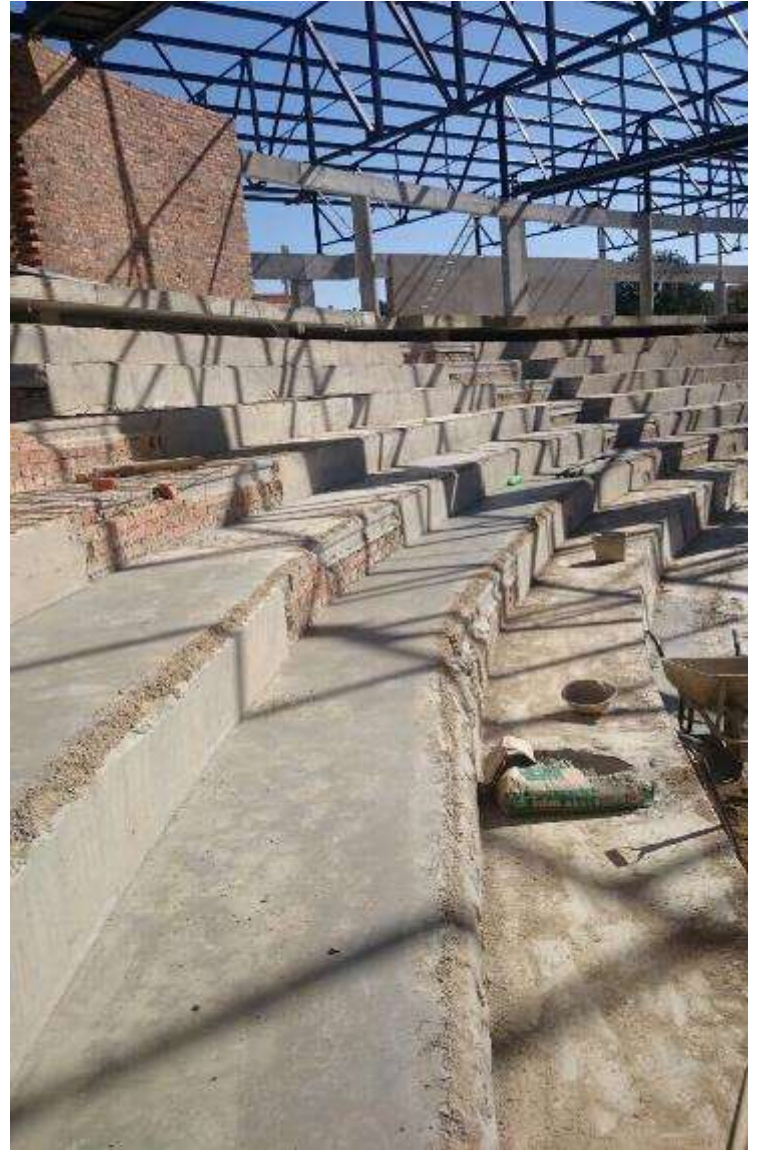

Various Walling Applications



“Believing in being more than precast hollow-core slabs manufacturer”



Mechanics of PC Hollowcore Retaining Walls

Gravity retaining walls

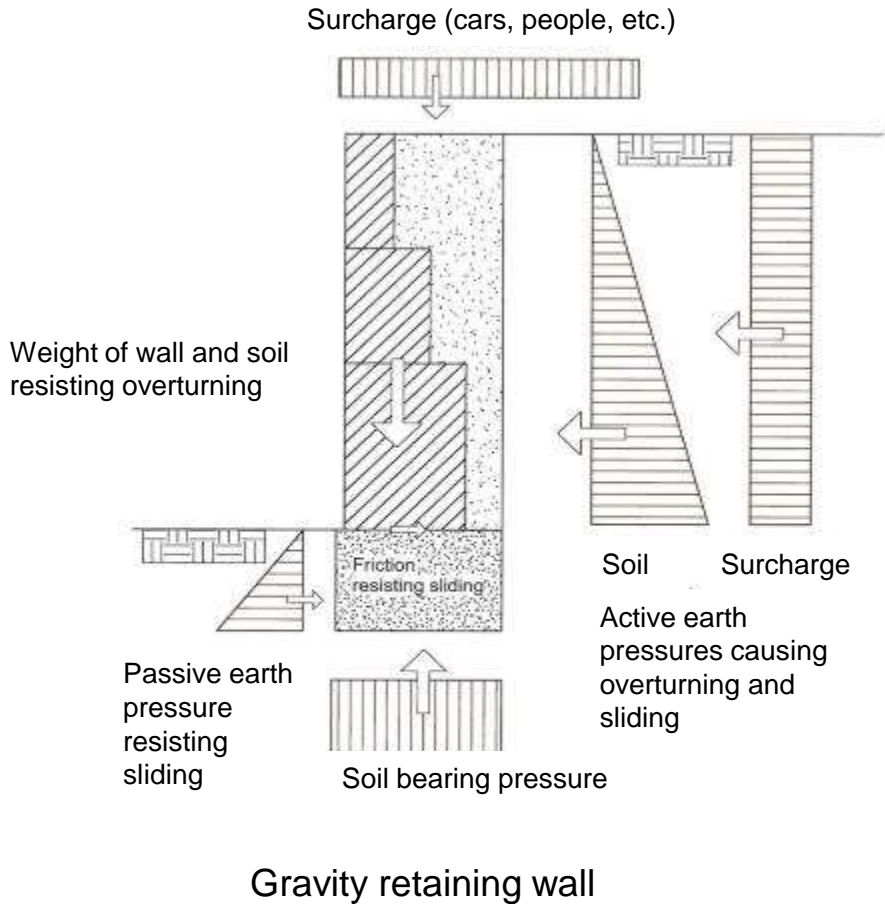

Mechanics of PC Hollowcore Retaining Walls

Cantilever retaining walls

Surcharge (cars, people, etc.)

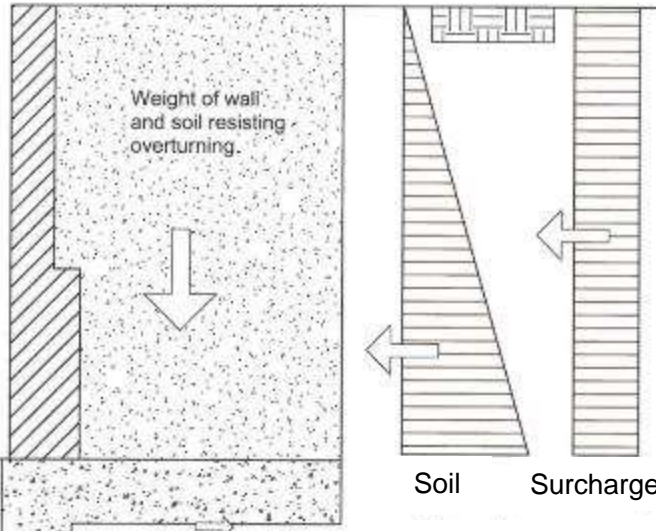
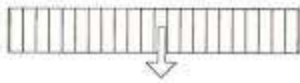

Active earth pressures causing overturning and sliding

Friction resisting sliding



Soil bearing pressure

Passive earth pressure resisting sliding

Cantilever retaining wall



Stretching the limits in a South African market









Innovation: Total HC Precast Solution

Total Area of Concrete:
149m²

Area of security wall slabs
29m²

Area of wall slabs
40m²

Area of floor slabs
18m²

Area of roof slabs
24m²

Area of foundations
20m²

Area of concrete columns
18m²

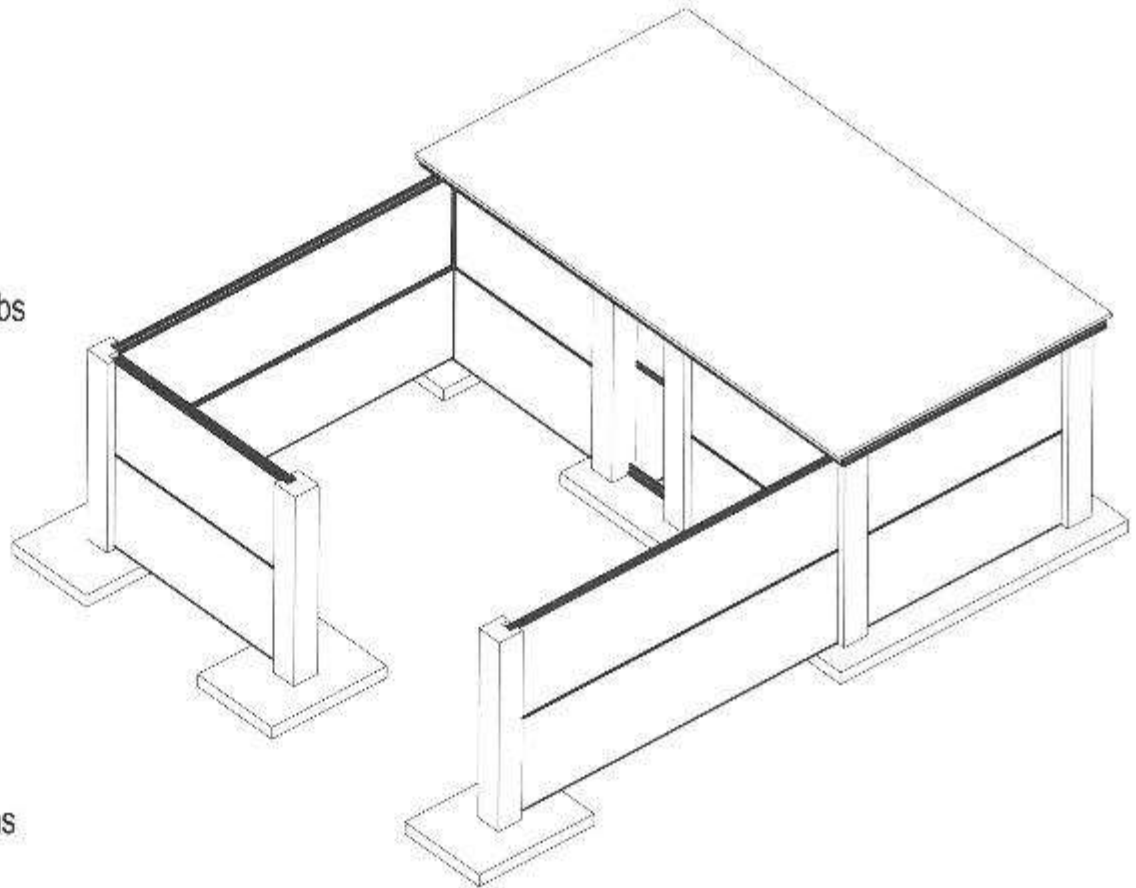

1 3D Perspective